

V62-7538HK-.25

Industrial UF Treated Membrane for Cathodic Paint Applications

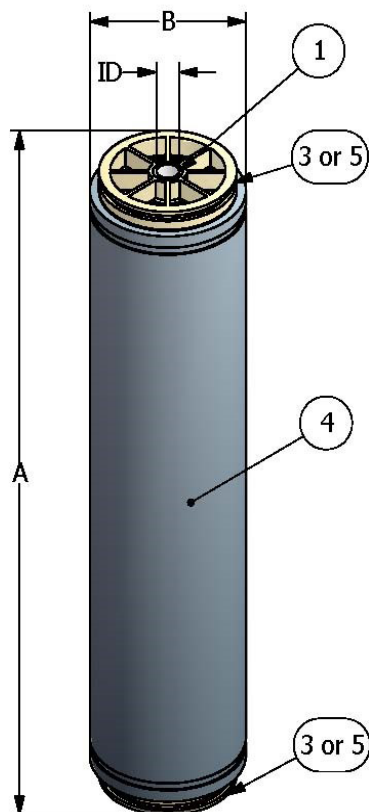
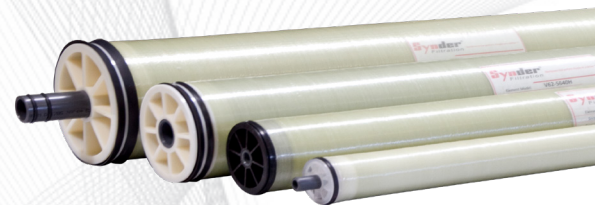

SPECIFICATIONS

Size:	8" Nominal
Outerwrap:	PVC Housing Shell
Element Design:	Spiral
Membrane:	PVDF 500kDa (Modified & Bonded)
Membrane Area:	288 ft ² (26.8 m ²)
Diameter:	8.63" (219.1mm)
Overall Length:	39.25" (997.0mm)
Weight:	50 ± 1.0 lb (22.7 ± 0.5 kg)
Housing Model:	Included

PERMEATE CAPACITIES

Permeate Output Steady State with Cationic Paint GPM (LPM)	2.60 ± 10% (9.8 ± 10%)
--	------------------------

OPTIMAL DESIGN PARAMETERS

Feed Rate:	75 GPM (284 LPM)
Element Inlet PSI:	50 PSIG (345 KPA)
Pressure Drop:	30 PSIG (207 KPA)

NOTE: Element performance may be affected by variances in operating parameters and feed chemistry.

ELEMENT LIMITS

pH Range:	1-11
Feed Rate:	60 / 80 GPM (227 / 303 LPM)
Inlet Pressure:	45 / 75 PSIG (310 / 517 KPA)
Pressure Drop:	25 / 35 PSIG (172 / 241 KPA)
Operation Temp:	120°F (48°C)

Item	Description
1	Permeate Tube (internal)
2	N/A
3	ATD
4	Element Body with PVC Shell
5	ATD
6	N/A

Item	Dimensions
A	39.25" (997.0mm)
B	8.63" (219.2mm)
C	N/A
D	N/A
ID	1.30" (33.0mm)

CONTACT US

4941 Allison Parkway
Vacaville, CA 95688
Phone: +1-707-451-6060
Fax: +1-707-451-6064
Email: sales@synderfiltration.com
support@synderfiltration.com
www.synderfiltration.com



INSTALLATION PROCEDURES

Note: HK spare parts kit does not come with the element and must be purchased separately. See drawing for assembly details. 10" HK elements and spare parts are available upon request.

1. Record the serial number of the new HK element.
2. Install new EPDM O-Rings on the bottom plug and lubricate with glycerin.
3. Lubricate the coupling gaskets with glycerin and push the large ones just onto each end of the PVC shell on the membrane.
4. Install the ATD, narrow end first and the new EPDM O-Rings on the permeate tube outlet end cap and lubricate with glycerin.
5. Loose fit the outlet end cap onto the top of the new membrane and measure the distance between the lower edge of the coupler clamp groove on the outlet end cap and the upper edge of the matching groove on the membrane. It should match the distance between the upper and lower lips on the inside of the coupler clamp.
6. Pull the coupler clamp gasket up equidistant between the outlet end cap and membrane, followed by the clamp halves and nuts and bolts.
7. Tighten the nuts and bolts to the clamp half clearance while removing them, while maintaining the lips into their respective grooves.
8. On the other end of the element, install the ATD, narrow end first. Insert the bottom plug into the membrane until it seats, and then loose fit the inlet end cap and adjust the clamp groove dimensions as shown in step 5 & tighten and secure the inlet end cap as shown in steps 6 and 7.
9. Install and hand tighten only the brackets to secure the completed membrane to the system frame and reconnect the flowmeter and inlet and outlet ports.
10. Circulate DI/RO water through the element for 15 minutes in the CIP loop. Purge to drain, and then refill with fresh DI/RO water. If this is not possible, soak the element in DI/RO water for at least one hour, purge to drain, and refill the housing with fresh DI/RO water.
11. Open both the paint permeate to rinse valve and the paint return valve.
12. Start paint feed pump and slowly open the paint feed valve (to fully open in 3 to 5 minutes). Adjust inlet pressure to a minimum of 50 psi. If your system is running, open your housing outlet and permeate valve. Then, very slowly open the housing inlet valve to fully open in 3 to 5 minutes to bring your element back online.
13. After the system runs for a few minutes, it may be necessary to re-adjust the pressures until the system balances out.
14. If you are running permeate to drain and are ready to change to permeate to rinse, open the permeate to rinse valve before closing the permeate to clean valve.
15. Start-up is now complete. Record the Serial No., Date, Permeate Output and Installer's Initials on the housing label provided with your new element.

Warning: When operating on paint or cleaning, the appropriate permeate transport valve must be 100% open. When operating on paint, the "Permeate to Rinse" valve must be 100% open. When cleaning, the "Permeate to CIP tank" valve must be 100% open. Throttling or closing any permeate valve while it's in operation can cause Leakers and Smokers and will void our Membrane Material & Workmanship warranty.

CLEANING PROCEDURES

Spiral Elements should be cleaned when the permeate rate has declined between 20%-30% from the steady state permeate rate that was recorded when either the element was installed initially or last cleaned. Steady state permeate rate is the rate that you record about 15-20 minutes after the element is initially put on the paint, or after the element has been thoroughly cleaned.

Note: The permeate rate should never drop more than 30% before an element is cleaned.

1. When initially cleaning an element, you should flush the paint from the element (preferably back to the paint tank) with UF permeate. If your system is large enough, and time permits, do this 2 more times. This helps with the cleaning process and helps recover as much paint as possible.
2. If UF permeate is unavailable, make up a solution of artificial permeate using DI/RO water and acetic acid. Adjust the heat and pH of the solution to that of the paint. Flushing the paint from the element with cold DI/RO water, you can "set" the paint on the element surface, making it difficult to clean. Confirm that this is acceptable with the paint manufacturer before proceeding.
3. After flushing the paint from the element, flush the element to drain. Start with a full heated cleaning tank of DI/RO water, pH adjusted to pH of the paint. Once you have started flushing the element to drain, open the DI/RO water fill valve to the cleaning tank to maintain the level in the cleaning tank. This will allow you to thoroughly flush the element to drain, while gradually lowering the temperature of the water.
4. When the flush water is reasonably clean from the element, slowly close the cleaning pump discharge valve and stop the pump.

SPECIAL RECOMMENDATIONS

Synder Filtration has formulated a concentrated cleaning product for use with our membranes and other spiral elements. The concentrate ratio is 1:99 and does not require the use of any solvents; uses muriatic acid (acetic and formic acid may be substituted for muriatic) and is usually effective in 60 minutes or less. The key to its success is cleaning at a pH of 2.0 to 2.2, maintaining a temperature between 100°F and 110°F, and cleaning before the permeate rate has decline too far. Contact us for more information on cleaning products and guidelines.

STORAGE PROCEDURES

6 Months or Less (Short Term)

Immediately following the final CIP flush, the system should be filled with 1% Sodium Metabisulfite (MBS) solution with a pH of 4.0-5.0. Every 7-10 days the following procedure should be performed:

1. Drain MBS solution from the system and flush to drain with clean water.
2. Run a caustic wash. (pH 10.8-11.0; 120-122°F; 15-20 minutes)
3. Flush to drain with clean water.
4. Recharge the system with a fresh bath of MBS.

Longer than 6 Months (Long Term)

A long term shutdown (over 6 months) can be handled easily and efficiently. This involves the removal of elements from the system, soaking them in preservative solution (vertically if possible), and sealing in a plastic bag for future use.

1. The preservative solution should include:
 - 20% Glycerine
 - 2% Sodium Metabisulfite
 - pH 4.0-5.0
2. Remove the element from the vessel, drain the elements in a vertical position to avoid extensive dilution of the preservative solution.
3. Place the element in a preservative for a minimum of 15 minutes.
4. Remove the element from the preservative and allow it to drain for approximately 10 seconds, then place the element back in the bag.
5. Seal the bag either via heat seal or waterproof tape. This should be done well to prevent any leakage during storage/transport.
6. Depending on the number of elements, the preservative solution may become diluted. In that event, add more preservative to maintain pH 4.0-5.0.
7. Element storage in 50°F - 59°F (10°C - 15°C) will increase storage life of the elements. If refrigeration is possible, it is highly recommended by Synder Filtration.
8. Contact Synder Filtration prior to storing any elements to discuss any remaining element warranty.